



---

## Design and Development of G.S.M. Based Industrial Process Monitoring and Control System

Oluwaleke A. Afolabi<sup>1</sup>, Ishaku A. Lucky<sup>2</sup>

<sup>1</sup>Electrical and information engineering dept., Achievers University Owo, Ondo State.

E-mail: [oluwaleke.aa@achievers.edu.ng](mailto:oluwaleke.aa@achievers.edu.ng)

<sup>2</sup>Department of Advanced Engineering, Blackpool and The Fylde College

E-mail: [Lucky.Ishaku@blackpool.ac.uk](mailto:Lucky.Ishaku@blackpool.ac.uk)

---

**Abstract:** GSM Based Industrial Process Monitoring and Control System is a microcontroller embedded system that is fully controlled by the 8-bit AVR Atmega32 microcontroller which has 32KB of flash memory for the program data storage. LM35 IC, GSM Modem, LCD screen, Relays (Process control devices), Matrix keypad are interfaced with the microcontroller unit. The embedded system is designed with on board power supply.

LM35 senses the temperature of the industrial processes, and the readings are continuously displayed on LCD and also sent wirelessly to the industrial operator's mobile set. The operator is able to control the status of the industrial process control devices by sending pass worded SMS commands which are different for each process device. The system sends feedback SMS notification about the status of the process control devices.

**Keywords:** process, control, embedded, industrial, microcontroller

---

### 1. Introduction

Industrial monitoring and control is the use of sensor technology and control systems such as computers to control industrial machinery and processes, reducing the need for human intervention hence increasing safety. In the scope of industrialization, monitoring and control is a step beyond mechanization. Whereas mechanization provided human operators with machinery to assist them with the physical requirements of work, monitoring and control greatly reduces the need for human sensory and mental requirements as well. Processes and systems can also be monitored and controlled. Engineers strive to combine automated devices with mathematical and organizational tools to create complex systems for a rapidly expanding range of applications and human activities.

Many roles for humans in industrial processes presently lie beyond the scope of automation. Human-level pattern recognition, language recognition, and language production ability are well beyond the capabilities of modern mechanical and computer systems. Tasks requiring subjective assessment or synthesis of complex sensory data, such as scents and sounds, as well as high-level tasks such as strategic planning, currently require human expertise. In many cases, the use of humans is more cost-effective than mechanical approaches even where automation of industrial tasks is possible. Specialized hardened computers, referred to as programmable logic controllers (PLCs), are frequently used to synchronize the flow of inputs from (physical) sensors and events with the flow of outputs to actuators and events. This leads to precisely controlled actions that permit a tight control of almost any industrial process.

Human-machine interfaces (HMI) or computer human interfaces (CHI), formerly known as man-machine interfaces, are usually employed to communicate with PLCs and other computers, such as entering and



monitoring temperatures or pressures for further automated control or emergency response. Service personnel who monitor and control these interfaces are often referred to as stationary engineers.

Moreover, industrial monitoring and control of industrial process devices (sensors, actuators, etc.) is very important and crucial to deliver an uninterrupted outputting several industries (Nuclear plants, power plants, petroleum and gas). This job should be done with at most accuracy and reliability. The sensor information should be available at various locations simultaneously to take accurate decisions. This kind of requirement can be met by using the central servers and connecting the sensor networks through the controllers to the central servers. Most of the systems require features which are given by web server kind of architecture on wireless authentication (of the person commanding) and port numbers for each connecting application. The deployment of the web server is costly and complex to maintain, maintaining the wireless network has issues.

GSM network is a readily available, wireless secured network. Growing technological research towards 3G suggests this alternative. So, to reduce the maintenance costs and to optimize critical industrial process monitoring and control of devices, this project presents a GSM Based Industrial Process Monitoring and Control System.

## 2. System Overview

This section discusses an overview of the existing technologies and devices used.

### Existing Technologies

Majority of the companies in developing countries have not implemented Automation practices in industry. Except few large industries majority of the companies cannot afford to invest huge amount of money in the existing costly setups to meet the requirements of Industrial Automation.

Existing methods widely use the following technologies to communicate the information from one end to the other end of the company.

- Using Bluetooth** -- But it is limited to short range.
- Using ZigBee/ IEEE802.15.4** -- Range is up to only few Kilometres maximum.
- Using Wi-Fi** -- Requires costly equipment setup and high-power consumption.

All the methods discussed above are quite expensive and complex to implement and not very reliable. The availability of information at various nodes simultaneously is not achieved.

### Bluetooth Technology

Bluetooth Technology is a radio frequency (RF)-based, short-range connectivity technology that promises to change the face of computing and wireless communication. It is designed to be an inexpensive, wireless networking system for all classes of portable devices. The projected cost of the Radio chip was around \$5.

A complete Bluetooth system will require these elements:

- An RF portion for receiving and transmitting data includes short-range radio transceiver, an external antenna, and a clock reference (required for synchronization)
- A module with a baseband microprocessor
- Memory
- An interface to the host device (such as a mobile phone)

Its normal range of operation is 10m (at 1mW transmit power) and can be increased up to 100m by increasing the transmit power to 100mW. The system operates in unlicensed 2.4 GHz frequency band, hence it can be used worldwide without any licensing issues. It provides an aggregate bit rate of approximately 1Mbps.

### ZigBee Technology

The ZigBee radio specification is designed for low cost and power consumption than Bluetooth. The specification is based on IEEE 802.15.4 standard. The radio operates in the same ISM band as Bluetooth and is capable of connecting 255 devices per network. The specification supports data rates of up to 250Kbps at a range of up to 30m. These data rates are slower than Bluetooth, but in exchange the radio consumes significantly with low power with a large transmission range. The goal of ZigBee is to provide radio operation for months or years without recharging, thereby targeting applications such as sensor networks and inventory tags.



The beauty of ZigBee is that devices from different manufacturers will be able to work together, as long as all are compliant to the standard. It has been suggested that the name evokes the haphazard paths that bees follow as they harvest pollen, similar to the way packets would move through a mesh network.

ZigBee is standardized at two levels – the radio chips must follow certain design rules, and the protocol layers that actually make the network function are defined and controlled by the ZigBee Alliance. Advantages are: Reliable and self-healing, Supports large number of nodes, Easy to deploy, Very long battery life, Secure and Low cost.

### Wi-Fi Technology

Wi-Fi is the name given by the Wi-Fi Alliance to the IEEE 802.11 suite of standards. 802.11 defined the initial standard for wireless local area networks (WLANs).

But because of its costly equipment setup and high-power consumption this technology is not preferred.

### GSM

GSM (Global System for Mobile communication) is a digital mobile telephone system that is widely used in Europe and other parts of the world. GSM uses a variation of Time Division Multiple Access (TDMA) and is the most widely used of the three digital wireless telephone technologies (TDMA, GSM, and CDMA). GSM digitizes and compresses data, then sends it down a channel with two other streams of user data, each in its own time slot. It operates at either the 900 MHz or 1,800 MHz frequency band.

GSM is an international digital cellular telecommunication.

The GSM standard was released by ETSI (European Standard Telecommunication Standard) back in 1989. In less than ten years since the first GSM network was commercially launched, it became, the world's leading and fastest growing mobile standard, spanning over 190 countries.

**Table 1:** GSM characteristics

Mobile Frequency Range	RX: 925-960; TX: 880-915
Multiple Access Method	TDMA/FDMA
Duplex Method	FDD
Number of Channels	124 (8 users per channel)
Channel Spacing	200kHz
Modulation	GMSK (0.3 Gaussian Filter)
Channel Bit Rate	270.833Kb

Global System for Mobile (GSM) is a second-generation cellular standard developed to deliver high quality and secure mobile voice and data services (such as SMS/ Text Messaging) with full roaming capabilities across the world using digital modulation. It is known as 2G digital which has a maximum data speed of 9.6Kbps and is based on circuit switched technology and provides short message service (SMS). The GSM network can be divided into three broad parts. The subscriber carries the Mobile Station. The Base Station Subsystem controls the radio link with the Mobile Station. The Network Subsystem, the main part of which is the Mobile services Switching Centre (MSC), performs the switching of calls between the mobile users, and between mobile and fixed network users. The MSC also handles the mobility management operations. The Mobile Station and the Base Station Subsystem communicate across the Um interface, also known as the air interface or radio link. The Base Station Subsystem communicates with the Mobile services Switching Center across the A interface.



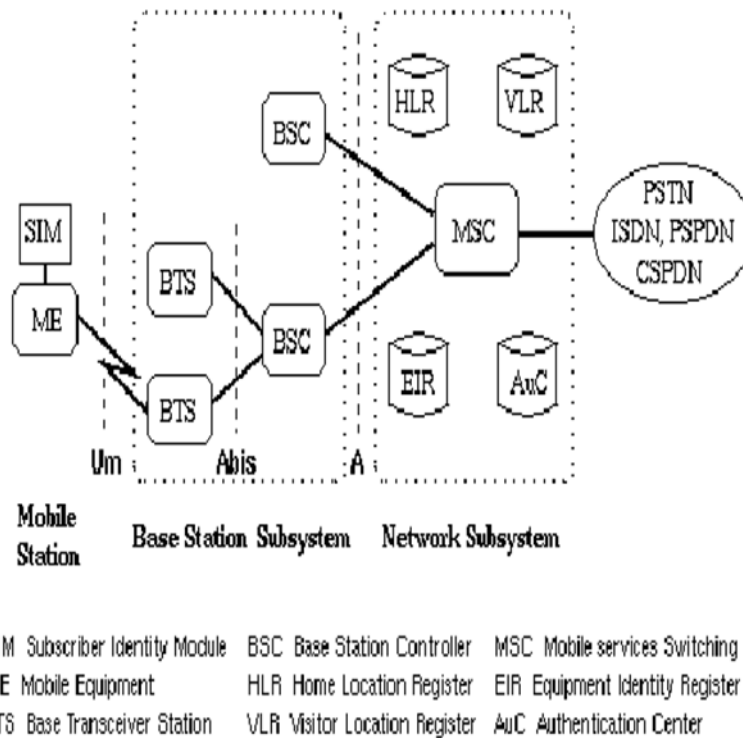

Figure 1: General architecture of a GSM network

The GSM standard provides a common set of compatible services and capabilities to all mobile users across Europe and several million customers worldwide. The basic requirements of GSM have been described in five aspects.

#### Services

The system shall provide service portability, i.e., mobile stations or mobile phones can be used in all participating countries. The system shall offer services that exist in the wire line network as well as services specific to mobile communications. In addition to vehicle-mounted stations, the system shall provide service to Mss used by pedestrians and /or on board ships.

#### Quality of Services and Security

The quality for voice telephony of GSM shall be at least as good as the previous analog systems over the practical operating range. The system shall be capable of offering information encryption without significantly affecting the costs to users who do not require such facility.

#### Radio Frequency Utilization

The system shall permit a high level of spectrum efficiency and state-of-the-art subscriber facilities. The system shall be capable of operating in the entire allocated frequency band, and co-exist with the earlier systems in the same frequency band.

#### Network

The identification and numbering plans shall be based on relevant ITU recommendations. An international standardized signalling system shall be used for switching and mobility management. The existing fixed public networks should not be significantly modified.

#### Cost

The system parameters shall be chosen with a view to limiting the cost of the complete system.

#### GSM Competing with SCADA

SCADA (Supervisory Control and Data Acquisition) systems are currently widely used in unmanned substations. The systems use wired communication mode including setting up cables or fibre-optic cables or renting telephone lines or ADSL from Telecommunication Corporations. However, it is not feasible to build SCADA systems for prefabricated substations, because of the great difficulties to setting up wired network to the remote areas and the high operating and construction cost.



SCOPE	GSM	SCADA
Advantages	<p><b>Cost Saving</b>-using public GSM network instead of setting up cables or renting specialized telephone lines.</p> <ul style="list-style-type: none"> <li>– <b>Smart</b>-microprocessor based monitoring system can function as self-diagnosis and automatic alarm.</li> <li>– <b>Mobility</b>-cell phones can function as mobile controllers to receive alarm and status data and to send simple commands.</li> <li>– <b>Easy for Expansion</b>-a newly built prefab-substation can be monitored by just installing a microprocessor-based device with a GSM/GPRS module on it.</li> </ul>	<ul style="list-style-type: none"> <li>- Higher reliability of data transmission.</li> <li>– More developed technology for centralized system control.</li> </ul>
Disadvantages	<p>Communication quality depends on the public GSM network traffic.</p> <ul style="list-style-type: none"> <li>– The Centralized administration system in control station still needs future development.</li> </ul>	<ul style="list-style-type: none"> <li>--Long construction period and high construction cost.</li> <li>– Cannot be monitored by mobile devices.</li> </ul>
Applications	Suitable for small-size substation distributed in wide areas power distribution system with a very large RTU number capacity.	Suitable for large scale substations.

Also, most SCADA systems only function as the data detection and transmission. The data processing and fault diagnosis will be done in control centre. So when using SCADA systems, the substations cannot be controlled by mobile controllers.

The GSM network that is run by Mobile Communication Corps. Provides reliable communication quality with nationwide coverage. Short message service (SMS) that is ideal for intermittent small packet data transmission has now become the most widely used value added service based upon GSM standard. Meanwhile, the decreasing cost of GSM network devices such as mobile phones and GSM module has made them an attractive option for other wireless communication applications. By utilizing GSM SMS and assigning a unique address (SIM card number) to each remote-control unit, data and commands can be transmitted in the wireless communication network. This paper presents design and implementation of a distributed monitoring and centralized controlling system for prefabricated substations. The system completely meets the demand of low cost and high-level automation by introducing the microprocessor based RTUs and mobile communication technology.

GPRS supports world's leading packet-based internet protocols that makes highly efficient use of radio spectrum and enables high data speed. It enables any exiting IP or X.25 application to operate over a GSM cellular connection. Its data speed varies from 115Kbps to 117Kbps but it is likely to average at 56Kbps. It was developed to enable GSM operators to meet the following key features:

- It is a step towards 3G.
- Higher bandwidth and therefore data speed.
- Seamless, immediate and continues connection to the internet—'always on-line'.
- New text and visual data content services.
- Packet switched rather than circuit switched which enable higher radio spectrum efficiency.

### Overview of the Devices Used

#### LM35

The LM35 series are precision integrated-circuit temperature sensors. Its output voltage is linearly proportional to the Celsius temperature for a large range of temperature values. The LM35 thus has an upper hand over linear temperature sensors calibrated in ° Kelvin, as the user is not required to subtract a large constant voltage from its output to obtain convenient Centigrade scaling. The LM35 need not use any external calibration or trimming to provide usual accuracies of  $\pm 1/4^\circ\text{C}$  at room (moderate) temperature and  $\pm 3/4^\circ\text{C}$  over a full  $-55$  to  $+150^\circ\text{C}$  temperature range.

#### Features of LM35

- Calibrated directly in ° Celsius (Centigrade)



- Linear + 10.0 mV/°C scale factor
- 0.5°C accuracy guarantee (at +25°C)
- Rated for full -55° to +150°C range
- Suitable for remote applications
- Low cost due to wafer-level trimming
- Operates from 4 to 30 volts
- Less than 60 μA current drain
- Low self-heating, 0.08°C in still air
- Nonlinearity only ±1/4°C typical
- Low impedance output, 0.1 W for 1 mA load.

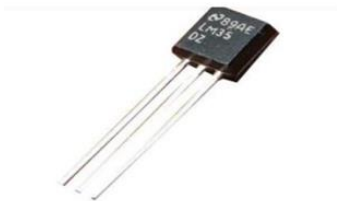

Figure 2: Plastic package LM35 DZ

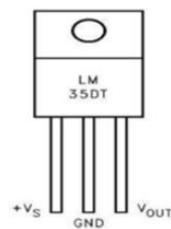

Figure 3: Pin layout

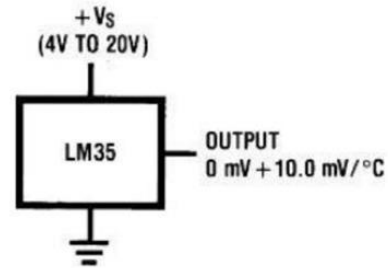

Figure 4: Voltage outputs

**LCD JHD162A**

A liquid-crystal display is a flat panel, electronic visual display that uses the light modulating properties of liquid crystals. Liquid crystal does not emit light directly. The working of LCD depends on two sheets of polarizing material with a liquid crystal solution in between them. When an electric current is passed through the liquid, it causes the crystals to align so that it blocks out light and does not allow it to pass [10]. Each crystal behaves like a shutter, it either allows light to pass through or blocks the light. It can function properly in the temperature range of -10°C to 60°C and has operating lifetime of longer than 50000 hours (at room temperature without direct irradiation of sunlight).

**Features of LCD JHD162A**

- Display Mode.....TN/STN
- Number of data line.....8-bit parallel
- Display type.....Positive Transflective
- Backlight.....LED(B/5.0V)
- Viewing direction.....6 o'clock
- Operating Temperature.....Indoor
- Driving Voltage..... Single power
- Type.....COB (Chip On Board)
- Connector.....Pin
- Driving method.....1/16 duty,1/5 bias
- Display construction.....16 Characters \* 2 Lines



Figure 5: 16X2 LCD

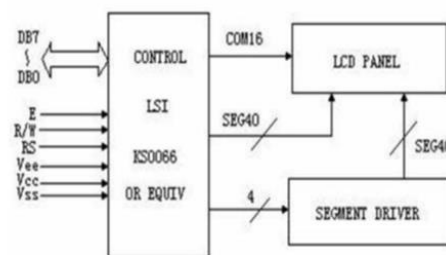

Figure 6: LCD and LCD Block Diagram

**Table 3:** Pin configuration of LCD

PIN NO.	SYMBOL	DESCRIPTION	FUNCTION
1	VSS	GROUND	0V (GND)
2	VCC	POWER SUPPLY FOR LOGIC CIRCUIT	+5V
3	VEE	LCD CONTRAST ADJUSTMENT	
4	RS	INSTRUCTION/DATA REGISTER SELECTION	RS = 0 : INSTRUCTION REGISTER RS = 1 : DATA REGISTER
5	R/W	READ/WRITE SELECTION	R/W = 0 : REGISTER WRITE R/W = 1 : REGISTER READ
6	E	ENABLE SIGNAL	
7	DB0	DATA INPUT/OUTPUT LINES	8 BIT: DB0-DB7
8	DB1		
9	DB2		
10	DB3		
11	DB4		
12	DB5		
13	DB6		
14	DB7		
15	LED+	SUPPLY VOLTAGE FOR LED+	+5V
16	LED-	SUPPLY VOLTAGE FOR LED-	0V

**SIM300**

SIM300 is a Tri-band GSM/GPRS engine whose working frequencies are EGSM 900 MHz, DCS 1800 MHz and PCS1900 MHz. SIM300 provides GPRS multi-slot class 10 capability and support the GPRS coding schemes CS-1, CS-2, CS-3 and CS-4.

This GSM Modem is compatible with any GSM network operator SIM card and behaves just like a mobile phone with its own unique phone number. Applications like SMS Control, remote control and data transfer can be developed easily using SIM300. [9]

The physical interface to the mobile application is made through a 60 pins board-to-board connector that provides all hardware interfaces between the GSM and customer's boards.

- The keypad and SPI LCD interface will give you the flexibility to develop customized applications.
- Two serial ports can help you easily develop your applications.
- Two audio channels i.e. two microphones inputs and two speaker outputs are present. This can be easily accessed by AT command.

**Features of SIM300**

- Single supply voltage of 3.4V – 4.5V.
- Typical power consumption in SLEEP mode to 2.5mA
- SIM300 works in Tri-band: EGSM 900, DCS 1800, and PCS 1900.
- Normal operation in temperature range of -20°C to +55°C
- Stores SMS in SIM card
- External Antenna is connected via 50 Ohm antenna connector or antenna pad.
- It has two serial interfaces.
- Timer function is programmable via AT commands.



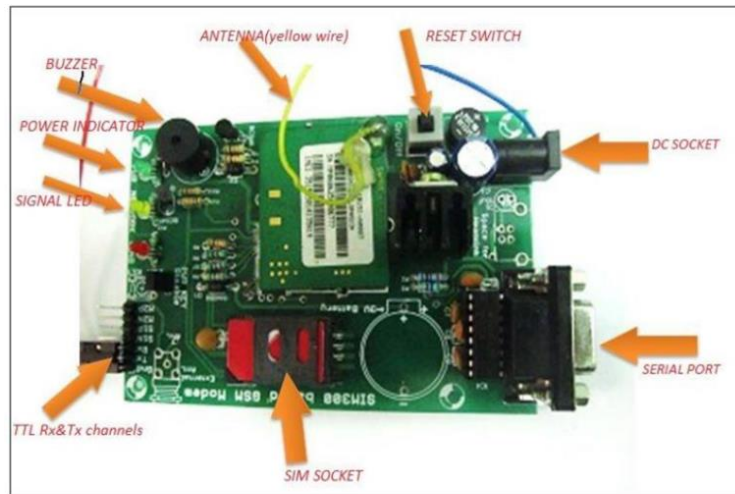

Figure 7: Overview of SIM300

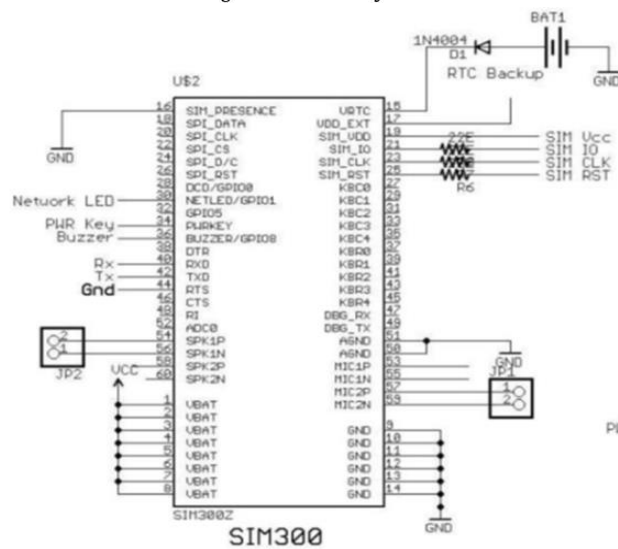

Figure 8: Block diagram & pin configuration of SIM300

**ATmega32**

The Atmel AVR ATmega32 is a low-power CMOS 8-bit microcontroller based on the AVR enhanced RISC architecture. By executing powerful instructions in a single clock cycle, ATmega32 achieves throughputs approaching 1MIPS per MHz allowing the system designed to optimize power consumption versus processing speed [4]. ATMEGA 32 Development Board is made from double sided PTH PCB board to provide extra strength to the connector joints. Power supply for the board ranges from 7 to 15V DC. It has built-in reverse polarity protection. It also has 7805voltage regulator. The heat sink dissipates the heat so that it can supply 1Amp current continuously without being over heated. It has switches for reset and power.



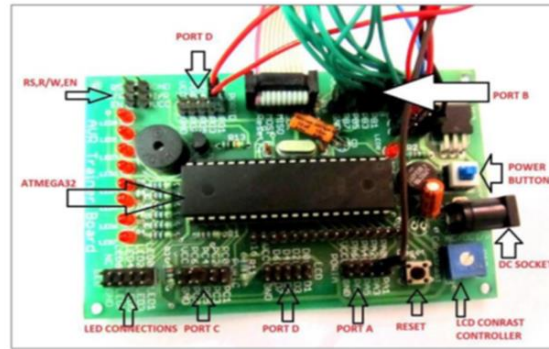

Figure 9: AVR Development Board

### Features of AVR Microcontrollers (ATMEGA-32)

- 32K bytes of ISP Flash Program memory with Read-While-Write capabilities.
- 1Kbyte EEPROM.
- A programmable Watchdog Timer with Internal Oscillator.
- 2K byte SRAM.
- 32 general purpose I/O lines.
- 32 general purpose working registers.
- A JTAG interface is available.
- On-chip debugging support and programming.
- Timer/Counters with compare modes.
- A serial programmable USART.
- A byte oriented Two-wire Serial Interface.
- An 8-channel, 10-bit ADC.
- An SPI serial port.
- 6 software selectable power saving modes.

### Architecture and Pin Configuration of ATmega32

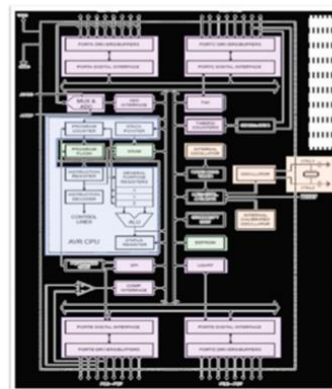

Figure 10: Architecture of ATMEGA 32

PDIP	
(XCK/T0) PB0	1
(T1) PB1	2
(INT2/AIN0) PB2	3
(OC0/AIN1) PB3	4
(SS) PB4	5
(MOSI) PB5	6
(MISO) PB6	7
(SCK) PB7	8
RESET	9
VCC	10
GND	11
XTAL2	12
XTAL1	13
(RXD) PD0	14
(TXD) PD1	15
(INT0) PD2	16
(INT1) PD3	17
(OC1B) PD4	18
(OC1A) PD5	19
(ICP1) PD6	20
PA0 (ADC0)	40
PA1 (ADC1)	39
PA2 (ADC2)	38
PA3 (ADC3)	37
PA4 (ADC4)	36
PA5 (ADC5)	35
PA6 (ADC6)	34
PA7 (ADC7)	33
AREF	32
GND	31
AVCC	30
PC7 (TOSC2)	29
PC6 (TOSC1)	28
PC5 (TDI)	27
PC4 (TDO)	26
PC3 (TMS)	25
PC2 (TCK)	24
PC1 (SDA)	23
PC0 (SCL)	22
PD7 (OC2)	21

Figure 11: Pin configuration

### Relay

Relay is an electromagnetic switch based on electromagnetic induction used to control the switching of an electrical device. The relay's switch connections are labelled COM, NC and NO

COM = Common, it is the moving part of the switch.

NC = Normally Closed, when the relay coil is off then the COM is connected to the NC.

NO = Normally Open, when the relay coil is on then the COM is connected to the NO.



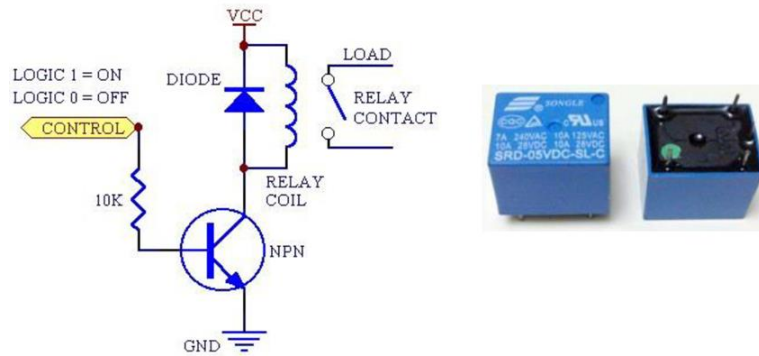

Figure 12: Relay and its Circuit Diagram

This project uses 12V DC relays to control the switching on and off of the industrial process loads.

### Matrix Keypad

A Matrix keypad consists of a set of pushbuttons which are interconnected. In this project, a 4X4 matrix keypad in which there are 4 rows and 4 columns is used.



Figure 13: Matrix keypad

### Buzzer

A piezoelectric buzzer/beeper is used in this project because of its portability and low power consumption. The buzzer beeps in case of a wrong system start-up password input to alert the authorities.



Figure 14: Buzzer

### Power Supply

The microcontroller and other devices get power supply from AC to Dc adapter through 7805, 5 volts regulator. The adapter output voltage will be 12V DC non-regulated. The 7805/7812 voltage regulators are used to convert 12 V to 5V/12V DC.



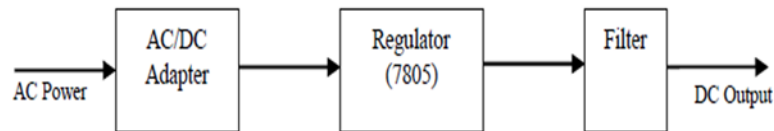

Figure 15: AC-to-DC Conversion

### Software Module

The program is written in Embedded C in AVR Studio 4. AVR Studio is an Integrated Development Environment (IDE) to write and debug AVR applications in Windows based operating systems; ex windows 8. AVR Studio provides a project management tool, simulator, assembler and source file editor for C/C++, emulation, programming and on-chip debugging .The project in AVR Studio is created under AVR GCC type. The AVR GCC plug-in is a GUI front-end to GNU make and avr-gcc. The build and run tool is WINAVR tool is used to convert C Language to HEX File. The HEX file is dumped into the ATmega32 microcontroller using SinaProg 1.3.5.6. [6]

### 3. Methodology

This section will explain the system design i.e. architecture and interfacing of the devices used in this project.

#### System Model

In this Project an attempt has been made to develop a GSM (Global System for Mobil communication) based industrial process monitoring and control system. Using the public GSM networks, an industrial process monitoring and control system has been proposed, designed, implemented and tested. The design of a stand-alone embedded system that can monitor and control various process and equipment and critical systems locally using built-in input and output peripherals is presented.

Remotely, the system allows the various authorities to monitor and control the critical parameters via the mobile phone set by sending commands in the form of SMS messages and receiving the process status. The GSM modem provides the communication media between the Authority and the system by means of SMS messages. The system software driver is also developed using an interactive C

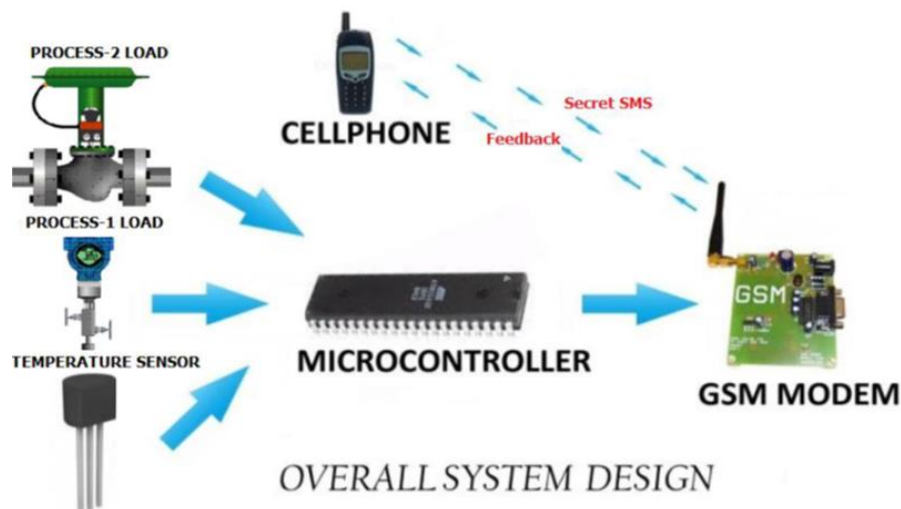

Figure 16: System Model

#### Basic Principle of System Model

- Atmega32 Microcontroller is interfaced with sensors, actuators, LCD display and with GSM modem.
- Atmega32 Microcontroller is programmed with the default control algorithm. The sensor information processed by the controller can be rooted to the users by power on controller sends status SMS to predefined numbers



- User can update the control algorithm by sending an SMS.
- User can get the status and change mode also by sending SMS.
- Modem performs the operation and gives acknowledgment message to the user.

**Working of System Model**

Micro controller is interfaced with sensors like Temperature, IR, Smoke sensors and actuators that control industrial processes. The basic idea of these sensors is to monitor the parameters of various systems. For example monitoring the boiler performance in a thermal / Nuclear power plant can be done by using Temperature of the boiler. If any increase in the temperature of the system beyond the threshold has been recorded, the controller is instructed to initiate a corrective action. At the initial phase the controller will send an SMS to the authorised user. Based on the information received the user can initiate the corrective action. In the above case the temperature can be brought down by controlling the heat input. The same instruction will be initiated by the user. After receiving the corrective command, the controller will activate the necessary modules to reduce the heat input.

The basic functionality of the smoke sensors is to control the parameters of the process based on the external parameters and uncontrolled combustion happening, because of the malfunction and break down of certain combustion process.

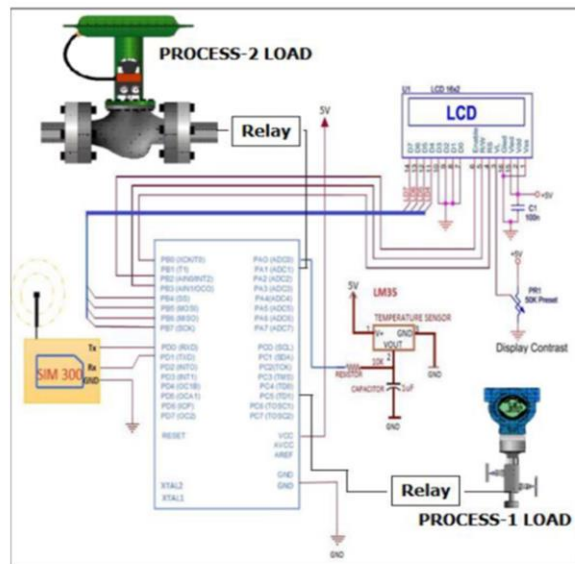

Figure 17: Total interfacing and circuit diagram

**Interfacing of Devices Used**

**LM35 interfacing with AVR Board**

Table 4: LM35 interfacing with AVR Board

LM35	AVR BOARD
Vcc	Vcc(5volts)
Output	Port A(Pin Pa0)
Gnd	Gnd

**Algorithm for ADC conversion with flowchart**

- The output of LM35 linearly varies with temperature.
- The output is in 10MilliVolts per degree centigrade.
- The ADC gives an output in the range of 0-1023 value.
- Each step is of size 5MilliVolts.



- If ADC value is X then Analog voltage value is  $X*5mVolts$ .
- Final TEMPERATURE= $(X*5)/10$  degree centigrade.

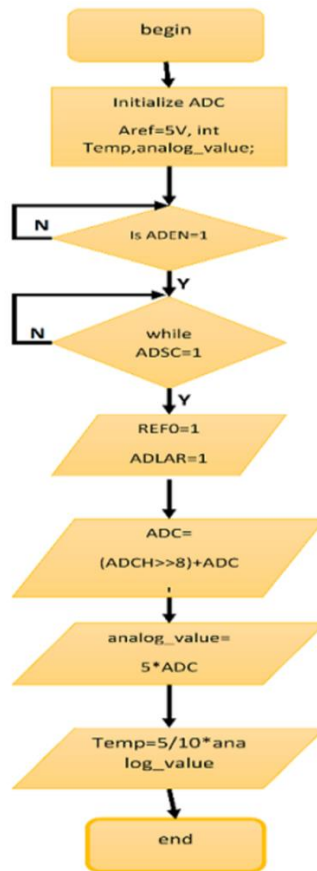

Figure 18: Flowchart for ADC Conversion

**LCD interfacing with AVR Board**

Table 5: LCD interfacing with AVR Board

LCD(JHD 162A)	AVR BOARD(PORT B)
Pin Number 1	GND
Pin Number 2	VCC(5V)
Pin Number 3	GND
Pin Number 4	PB0
Pin Number 5	PB1
Pin Number 6	PB2
Pin Number 7	Left Open
Pin Number 8	Left Open
Pin Number 9	Left Open
Pin Number 10	Left Open
Pin Number 11	PB4
Pin Number 12	PB5
Pin Number 13	PB6
Pin Number 14	PB7
Pin Number 15	VCC
Pin Number 16	GND

**Application Editor**

Application Editor is used for writing programs, which can be done using assembly or C. Application Editor itself, bears much resemblance to IDE-s of other standard 8-bit microcontrollers. Left side window holds list of files that are contained in current project. Most important file for users is called main.



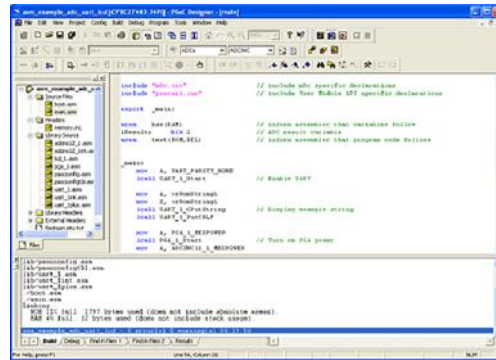

### Sample Firmware Source Code

```
//-----
// C main line
//-----
#include <m8c.h> // part specific constants and macros
#include "PSoC API.h" // PSoC API definitions for all User Modules
#include <stdlib.h>
Char TextBuff [5];
Unsigned char TL SB, TMSB, TempI, j;
Int TempP;
Void main ()
{
LCD_1_Start ();
LCD_1_Position(0,0);
OneWireSW_1_Start (); // Initialize 1-Wire pin.
//OW_1_Start ();
while(1)
{
OneWireSW_1_Reset (); // Reset the 1-Wire device.
OneWireSW_1_WriteByte (0xCC); // Skip ROM command.
OneWireSW_1_WriteByte (0x44); // Convert Temperature command.
OneWireSW_1_Delay10mTimes (90); // Wait 900 ms for the temperature conversion.
OneWireSW_1_Reset (); // Reset the 1-Wire device.
OneWireSW_1_WriteByte (0xCC); // Skip ROM command.
OneWireSW_1_WriteByte (0xBE); // Read Scratch Pad command.
TL SB = OneWireSW_1_ReadByte (); // Read LSB data.
TMSB = OneWireSW_1_ReadByte (); // Read MSB data.
TempP = (TMSB << 4) & 0xF0; // Integer number.
TempI = (TL SB >> 4) & 0x0F;
TempI = TempI | TempP; // Temperature in integer format
TempP = TL SB & 0x0F; // Binary point of temperature.
iota (TextBuff, TempI, 10); // Convert data to ASCII.
LCD_1_Position (1, 0);
LCD_1_PrCString ("TEMP = ");
LCD_1_PrString (TextBuff);
TempP = (TempP & 0x000f)* 625; // Convert data to decimal point for display.
iota (TextBuff, TempP, 10); // Display decimal point.
if (TempP < 1000)
LCD_1_PrCString (".0");
else
```



```

LCD_1_PrCString (".");
LCD_1_PrString (TextBuff);
LCD_1_PrCString (" C ");
}
}
    
```

**Writing commands in LCD in 4 bit mode**

- LCDs have both 4-bit and 8-bit mode.
- First command should be sent in 8-bit mode, after that it should send a command to the LCD to operate in 4-bit mode.
- Since pin 7-10 are connected to ground on the LCD panel, we must use the 4-bit communication mode.
- The LCD defaults to 8-bit mode.
- Function set DL — specifies the interface data length
  - 0-4 bit mode
  - 1-8 bit mode

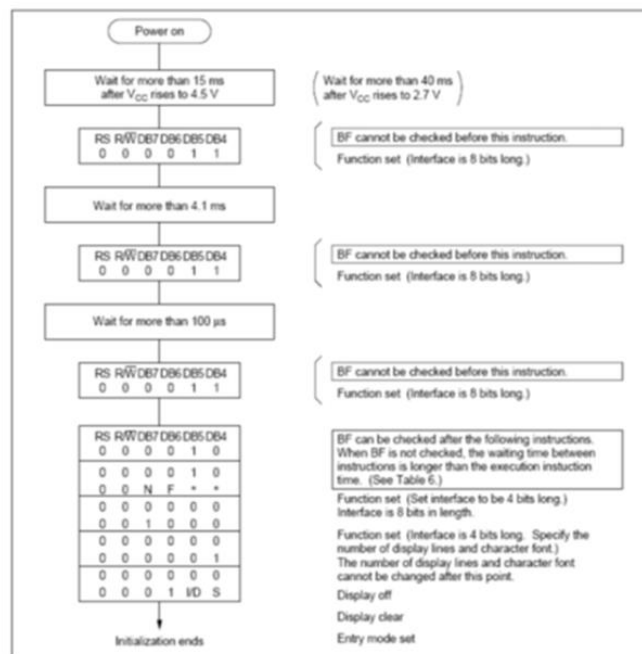

**Figure 19: LCD 4 bit interface**

**SIM300 interface with AVR Board**

**Table 6: SIM300 interface with AVR Board**

SIM300	AVR BOARD
Vcc	Vcc(12Volt)
Gnd	Gnd
Tx	PD0(PORT D)
Rx	PD1(PORT D)

**Algorithm for checking the sim300 using PC**

- Insert a SIM card on the board into the SIM tray.
- Attach the board to the computer’s USB port using a RS232 to USB serial cable.

- To read the text being sent by the modem windows has a built in serial monitoring software called HyperTerminal. Find it at Start ->> Programs - >>Accessories ->> Communications ->>HyperTerminal
- Enter connection name.
- Select the serial port at which the modem is connected under the “Connect Using” option.
- Select Baud rate 9600(default) and Flow control none. The GSM module works on a serial communication as well as TTL interface that can work within a range of speeds from 1200 bps to 1152000 bps.
- Enter “AT” in the HyperTerminal; the board will respond “OK” if all the things are connected correctly.
- The yellow LED is used to display the network status.
- LED Off means SIM300 is not receiving signal.
- 64ms to 0.8 Sec Off means SIM300 is having weak or no network.
- 64ms to 3 Sec Off means SIM300 found network.

#### 4. Results And Discussion

This section will describe the results and output of the system design.

##### System Evaluation

The following steps were collectively carried out to test; the quality of design, efficiency and also the reliability of the developed system.

**Step 1:** System start-up (power-up / boot)

**Step 2:** Enter the initial authentication system start-up password via the keypad to be able to switch on industrial system sensors and process control devices.

**Step 3:** A notification is then displayed on the LCD display upon successful password input and access control is granted.

**Step 4:** A wrong initial authentication password entered through the keypad triggers the buzzer to beep and interrupts the entire system hence no access control is granted.

LM35 senses the temperature of the industrial processes and the data is sent to MCU. Crystal-oscillator generates frequency of 11.0952MHz used for operation; the data is stored in EPROM chip which is simultaneously displayed on LCD. Microcontroller stores the digital data after converting the Analog data from sensor unit through ADC, for some delay unit of time (here 200ms) and resets the reading in MCU as well as in LCD.

The system is programmed to display data on LCD continuously. Once the temperature goes above 50 °C, An alert message is displayed “max temp” on LCD. At the same time it sends a message to the programmed number which reads “max temp reached” through the GSM Modem. Once the temperature goes below 50°C the MCU displays a message on LCD which reads “temp now stable” and at the same time it sends notification to the mobile station saying “temperature now stable”. 35

##### Results

Below is the list of figures in which LCD displays the output as per changing process temperature:

##### 1. Condition (temp<50)

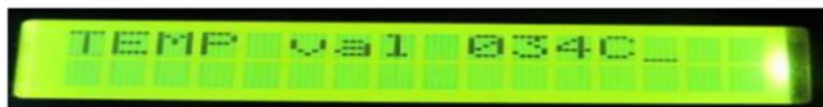

Figure 22: The temperature is continuously being displayed till it is below 50 degree

The temperature is continuously being displayed till it is below 50 degree.

##### 2. Condition (temp>50)



Figure 23: When the temp exceeds 50 degree





When the temp exceeds 50 degree it displays an alert message that “maximum temperature is reached”. Before sending SMS the LCD displays the message as in figure below.



*Figure 24: before sending SMS*

After the SMS is successfully sent the LCD displays the following message as displayed below.

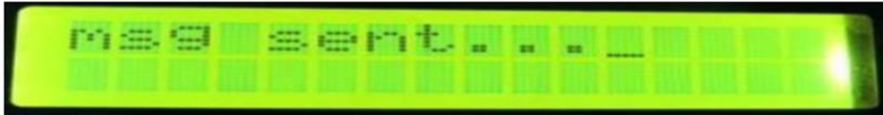

*Figure 25: After the SMS is successfully sent*

#### Condition (temp<50)

When the temperature once again falls back below 50°C the following message is displayed as shown below

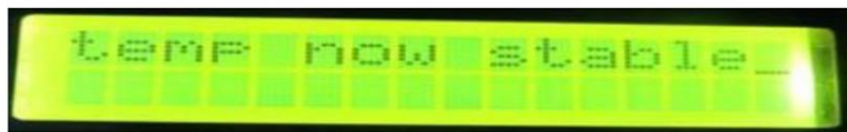

*Figure 26: When the temperature once again falls back below 50°C*

Action can be taken to control the industrial process control devices by switching them ON or OFF depending on the sent sensor data to the GSM phone of the industrial operator. The following results were obtained.

**Table 7: Output results Obtained**

S/N	ACTION TAKEN	RESULTS
<b>Phone Action</b>		
1	pcd1on	Process Control Device 1 ON
2	pcd1off	Process Control Device 1 OFF
3	pcd2on	Process Control Device 2 ON
4	pcd2off	Process Control Device 2 OFF
<b>Keypad Action</b>		
5	1234#	System start-up
6	Wrong password#	System Interrupt (Buzzer beeps)

#### Discussion

GSM Based Industrial Process Monitoring and Control System is a microcontroller based project and can be implemented practically as displayed. In this project the temperature sensor (LM 35), and process control devices are connected to ATMEGA32 microcontroller and the temperature readings and device status of the industrial process control devices are captured and sent to distant Mobile station of the industrial operator through the GSM modem. These data are simultaneously displayed on LCD. Based upon the experimentation and implementation, I came to observe that the temperature sensor data helps the operator to monitor the industrial process control devices and is able to control the devices based on the data relayed through GSM.



*Figure 27: Working model of GSM Based Industrial Process Monitoring and Control System*



## 5. Conclusion

This research project undertaken has helped the authors gain a better perspective on various aspects related to my course of study as well as practical knowledge of electronic equipment and communication. They became familiar with software analysis, designing, implementation, testing and maintenance concerned with my project. In this Critical sensor monitoring, authentication is commanding the system and wireless network are the challenges faced by the industries such as nuclear plants and power plants. The one wire protocol used for the temperature sensor helps for sensing temperature over a large area. As the user operates the system by a secret code the authorization problem has been solved.

The GSM network used helps in controlling the system from a distant area. The microcontroller used helps in interfacing many input/output devices at a time. These extensive capabilities of this system are what make it so interesting. From the convenience of a simple cell phone, a user is able to control and monitor virtually any electrical devices. The end product will have a simplistic design making it easy for users to interact with.

## Recommendations

This research project is a small implication of my concept in automating and monitoring systems. The practical applications of this project are immense and can have vast level of implementation. This small concept can be used in fields such as weather forecasting, remote sensing, robotics, aeronautics, home automation, and many other related fields where continuous monitoring and regulation is needed. So, this is not the end of the project but rather is a step towards exploring other possibilities that it brings with it. This project has tremendous application and possibilities.

## References

- [1]. Manashti, M.J., Ghamarnia, H., Amirian, S., & Nezhad, R.M. (2012). Design GSM-SMS based system for old, structured greenhouses with monitoring and logging network sensors. *International Research Journal of Applied and Basic Sciences*, vol. 3, pp. 1497-1507.
- [2]. Murugan, T., Periasamy, A., Muruganand, S. (2012) Embedded based Industrial Temperature Monitoring System using GSM, *International Journal of Computer Applications*, vol. 58, p. 0975 – 8887.
- [3]. Raghu K. G., Fan Y., and Hui L. (2011) Mobile Crowd sensing: Current State and Future Challenges, *IEEE Communications Magazine*.
- [4]. ATmega32 Datasheet, Atmel Corp., 2006. LM35 precision centigrade temperature sensors datasheet, National Semiconductors.
- [5]. Subhani Sk. M., Sateesh, G. N. V., Chaitanya, Ch., and Prakash B. G. (2013) Implementation of GSM Based Heart Rate and Temperature Monitoring System, *Research Journal of Engineering Sciences*, vol. 2, pp. 43-45.
- [6]. "Hitachi HD44780 LCD controller," Hitachi, 1998. [Online]. Available at: [https://en.wikipedia.org/wiki/Hitachi\\_HD44780\\_LCD\\_controller](https://en.wikipedia.org/wiki/Hitachi_HD44780_LCD_controller).
- [7]. "SIM300 datasheet," [Online]. Available at: [https://en.wikipedia.org/wiki/Liquid-crystal\\_display](https://en.wikipedia.org/wiki/Liquid-crystal_display).
- [8]. "Microcontroller to sensor interfacing techniques," BiPOM Electronics INC., [Online]. Available at: [www.bipom.com](http://www.bipom.com).
- [9]. Wellem, T. and Setiawan B. (2012) A Microcontroller- based Room Temperature Monitoring System, *International Journal of Computer Applications*, 53(1)
- [10]. Ding, J. Z., Ma, B. (2009) Remote monitoring system of temperature and humidity based on GSM, 2nd International Congress on Image and Signal Processing, Tianjin, China, 2009, pp. 1-4.

