



Design and Implementation of an Adaptive Timing Circuit for Electric Ovens

Akindele OA¹, Sadiq MO¹, Adejumobi OK²

¹Electrical Engineering Department, The Polytechnic, Ibadan, Nigeria

²Computer Engineering Department, The Polytechnic, Ibadan, Nigeria

Abstract This Paper presents the ‘Design and Implementation of an Adaptive Timing Circuit for Electric Oven’. Heat has become an indispensable form of energy in daily activities and electric oven is one of the best applications of heat energy which is used for cooking, baking roasting etc. Observation shows that the timing unit of most electrical appliances such as electric Oven etc continues its operation even when there is power interruption. The aim of this Paper therefore is to improve on the existing electric Oven through the incorporation of an adaptive Timing circuit that stops its operation whenever there is power interruption and continues from where it stops when power is restored. The major component used is the microcontroller programmed in Micro- C. The developed Oven with the Adaptive Timing circuit was tested and it worked according to specifications. It was also tested on existing electric Ovens in order to determine its functionality and effectiveness, and it worked perfectly. However, it is recommended that the designed timing unit be incorporated into new Ovens’ design.

Keywords Electric Ovens, Timing Circuit, Adaptive, Power Interruption, Temperature Control

1. Introduction

Cooking and drying are traditional methods for eating and preserving food [1]. An oven is a thermally insulated enclosure used for heating, baking or drying of a substance. The different types of baking oven are Earth, Ceramic, Gas, Masonry and Electric ovens. In science and Engineering laboratories, it is in form of a small furnace which is used in the removal of moisture from some Engineering materials in order to improve their physical properties such as ductility and hardness [2]. However, an Electric oven has several advantages over other baking ovens. It is easy to install, portable and has a very easy mode of operation, maintenance and high durability [3]. Ovens have been used since prehistoric times by 3200 BC [4]. Over the years, improvements have been made in electric ovens and this trend still continues. This has led to the incorporation of features such as thermostat which turns the oven ON and OFF and helps in regulating the temperature of the electric Oven. A timer is also incorporated into the oven to be turned ON and OFF automatically at pre-set times. Also, a microcontroller based time aware oven is an automatic time control oven that monitors a preset time and regulates the oven temperature over the set time [5]. If the temperature of the oven increases or reaches the set maximum, the heating element is automatically turned OFF, but when the temperature reduces, the heating element is also automatically turned ON. This ON and OFF activities take place within the set time given to the controlling unit, say ten (10) minutes, and when the time runs out, the oven is automatically turned OFF [6]. Solar energy has also been utilized in some designs of Ovens for cooking different agriculture products and in the food processing industries, research laboratory etc [7, 8].

2. Design Analysis

This design is divided into Hardware and Software Sections.



Hardware Section

The hardware Section is divided into two units, namely the Mechanical unit which consists of the housing unit and the Electrical Unit which consists of six (6) Modules namely; Power Supply, Setting Switches, Microcontroller, TRIAC, Heater and LCD Display (see Figures 1 and 2).

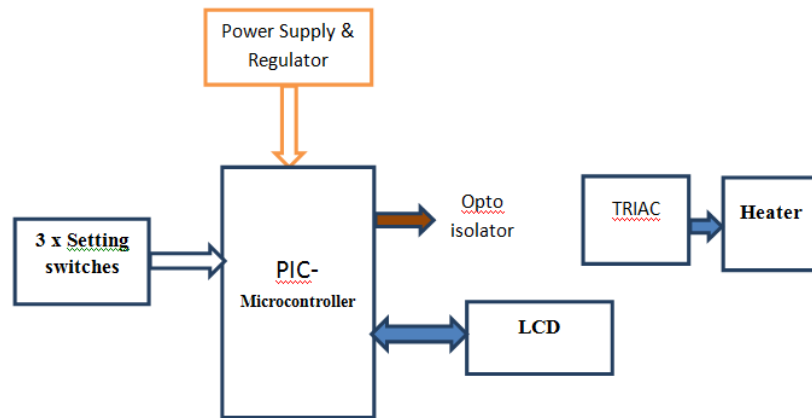

Figure 1: Block Diagram of the Developed Timing Unit for Electric Ovens

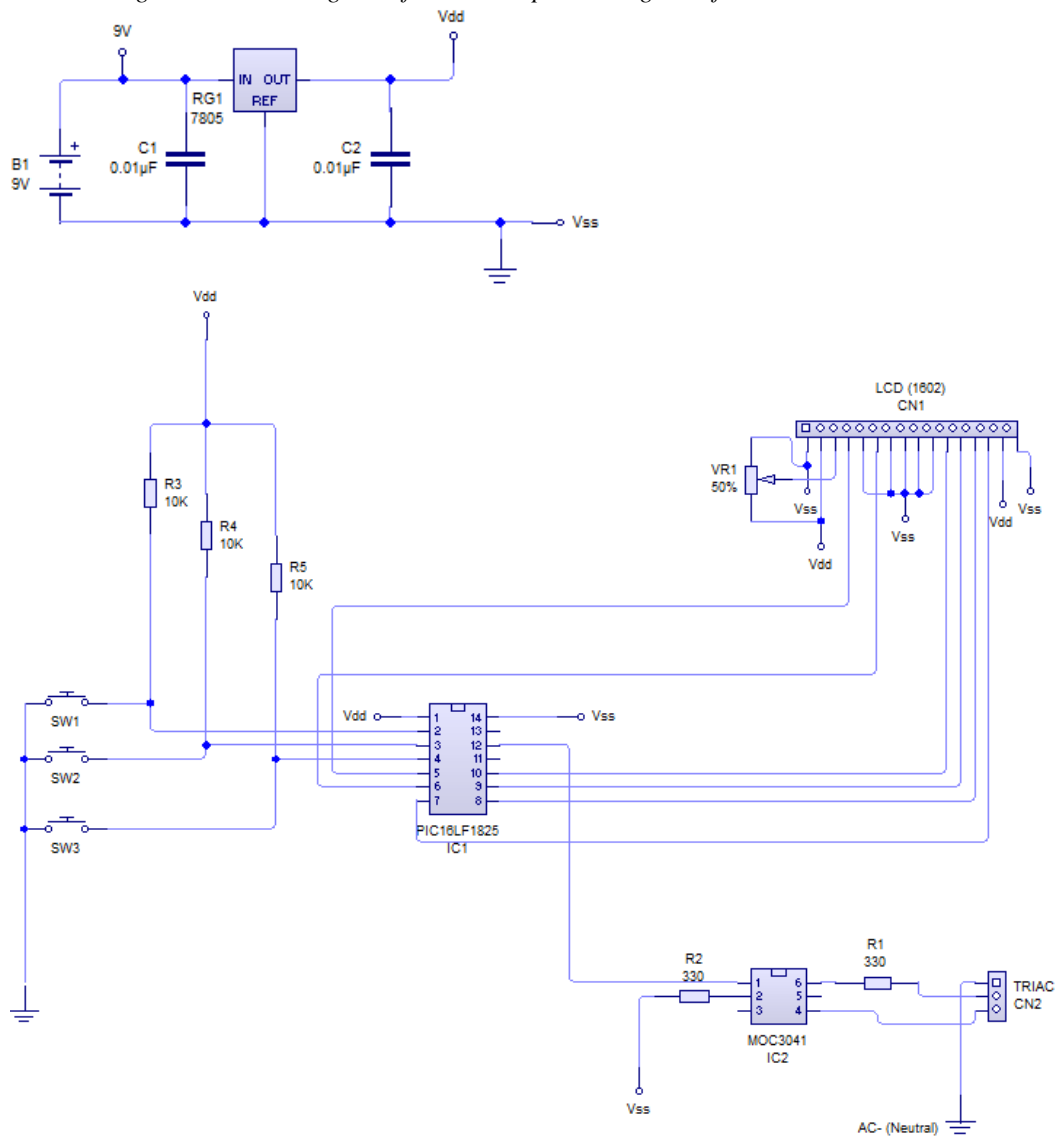

Figure 2: Circuit Diagram of the Developed Timing Unit for Electric Ovens

2.1.1. Capacity of the Oven

The capacity is in terms of the number of loaves of bread the oven can process per batch.

$$\begin{aligned} \text{Size of Tray} &= 29.8\text{cm (length)} \times 25\text{cm (width)} \\ &= 745\text{cm}^2 \end{aligned}$$

$$\text{Size of loaf of bread considered} = 18\text{cm (length)} \times 14\text{cm (width)} = 252\text{cm}^2$$

$$\text{Capacity of Oven} = \text{Size of tray} / \text{Size of Bread} = 745/252 = 2.96 \text{ loaves of Bread}$$

2.1.2. Heater Parameter

$$\text{Power (P)} = IV = (4.55 * 220) = 1\text{kW}$$

$$\text{Voltage (V)} = 220\text{V}$$

$$\text{Resistance (R)} = 48.3\Omega$$

$$\text{Current (I)} = 4.55\text{A}$$

2.1.3. Housing/Casing

$$\text{Height (h)} = 28\text{cm}$$

$$\text{Length (L)} = 30\text{cm}$$

$$\text{Area (A)} = 840\text{cm}^2$$

2.2. Software Section (see Appendix A)

The Design Program is written in Micro- C Language and was loaded on the microcontroller.

3. Testing and Discussion

The electric oven works on the principle of electric resistance. The resistance to current flow causes the heating element to be heated. The voltage indicator shows a Green light confirming the presence of current. As soon as the switch is turned ON, the indicator shows Red indicating that the oven is in operation. Heat generated by the heating element is dissipated within the oven chamber and by convection, is transferred to the metal pans placed on the wire mesh inside the housing unit. Since the loaf of bread is in direct contact with the tray, greater heat is transferred into it mainly by conduction. In case of Power interruption, the oven is disconnected from power source and the Timing Circuit stops the Clock's operation. However, when the Power is restored, the Oven continues its operation from where it stopped to complete the preset time allocation.

4. Conclusion and Recommendations

A newly designed electric Oven with an Adaptive Timing Circuit was implemented and tested. The Adaptive Timing Circuit designed was also incorporated into an existing electric Oven to check for its functionality, adaptability and effectiveness. In both cases, the design worked according to specifications.

Finally, the improved design is recommended for electric Oven's future designs.

Appendix A (Program Code)

```
#define finish_address 0x10
#define timer_address 0x20
#define secs_address 0x21
#define mins_address 0x22
#define counter_address 0x30
#define csec_address 0x31
#define cmin_address 0x32
#define pwr_address 0x40
#define ee_address 0x50
#define debounce 500
```

```
// LCD module connections
sbit LCD_RS at RC5_bit;
```



```
sbit LCD_EN at RC4_bit;
sbit LCD_D4 at RC0_bit;
sbit LCD_D5 at RC1_bit;
sbit LCD_D6 at RC2_bit;
sbit LCD_D7 at RC3_bit;

sbit LCD_RS_Direction at TRISC5_bit;
sbit LCD_EN_Direction at TRISC4_bit;
sbit LCD_D4_Direction at TRISC0_bit;
sbit LCD_D5_Direction at TRISC1_bit;
sbit LCD_D6_Direction at TRISC2_bit;
sbit LCD_D7_Direction at TRISC3_bit;
// End LCD module connections

sbit Heater at RA1_bit;
sbit start at RA3_bit;
sbit set_up at RA4_bit;
sbit set_down at RA5_bit;

unsigned long int timer, timer_counter ;
unsigned short secs, mins, csecs, cmins;
char start_flag, finish_flag, ee_flag, pwr_interruption;
char eepr;
char ii;
char i;
unsigned char op[12];
char lcd[8];
//void display(unsigned int timing, int row, int col);
void lcd_display(int sec, int min);
void settings();
    //12345678901234
char text[]="  secs" ;
char cnt =0;
//long int ck = 0;
void Interrupt(){
    if (TMR1IF_bit){
        TMR1IF_bit = 0;
        TMR1H      = 0xB1;
        TMR1L      = 0xE0;
        //Enter your code here
        cnt++;
        if(cnt == 36)
        { cnt = 0;
            timer_counter++;
            csecs++;
            if(csecs > 59)
            { csecs = 0;
                cmins++;
            }
        }
    }
}
```



```

    }
}
}

//Prescaler 1:4; TMR1 Preload = 15536; Actual Interrupt Time : 100 ms
//Place/Copy this part in declaration section
void InitTimer1(){
    T1CON    = 0x01;
    TMR1IF_bit    = 0;
    TMR1H    = 0xB1;
    TMR1L    = 0xE0;
    TMR1IE_bit    = 1;
    INTCON    = 0xC0;

}

void main() {
    ANSELA = 0;
    ANSELB = 0;
    OSCCON = 0x6B;    //0111_1011 16Mhz
    TRISA= 0x38;    //0011_1000
    OSCTUNE = 0x1F;
    InitTimer1();
    //WPUA5_bit = 1;    //enable Weak pull up
    // WPUA4_bit = 1;
    // WPUA3_bit = 1;

start_flag = 0;

//timer = 1;

    Lcd_Init();    // Initialize LCD
    Lcd_Cmd(_LCD_CLEAR);    // Clear display
    Lcd_Cmd(_LCD_CURSOR_OFF);    // Cursor off
    lcd_out(1,1, "Set:") ;
    lcd_out(2,1,"Timer:");
    TMR1ON_bit = 1;
    /*while(1)
    {
        lcd_display(csecs,cmins);
        lcd_out(2,7,text);
    }*/

    ee_flag = EEPROM_READ(40);
    // display(ee_flag,1,15);

    while(1)
    { settings();
        if(!start || !pwr_interruption )

```



```

{ while(!start);
delay_ms(400);
  TMR1ON_bit = 1;
  finish_flag = 0;
  EEPROM_WRITE(finish_address, finish_flag);
  pwr_interruption = 0; // power interruption
  EEPROM_WRITE(pwr_address,pwr_interruption);
  Heater = 1;

while(1)
{ //timer_counter = EEPROM_READ(counter_address);

  csecs = EEPROM_READ(csec_address);
  cmins = EEPROM_READ(cmin_address);
  lcd_display(csecs,cmins);
  lcd_out(2,7,text);
  timer_counter = cmins;
  timer_counter = timer_counter << 8;
  timer_counter = timer_counter | csecs;

  EEPROM_WRITE(csec_address,csecs);
  EEPROM_WRITE(cmin_address,cmins);
  if(timer_counter >= timer ) //if count up finished
  { Heater = 0;
  // timer = 0; //clear timer
  // TMR1ON_bit = 0;
  // timer_counter = 0; //clear timer_counter
  secs = 0;
  mins = 0;
  EEPROM_WRITE(secs_address,secs);
  EEPROM_WRITE(mins_address,mins);
  csecs = 0;
  cmins = 0;
  EEPROM_WRITE(csec_address,csecs);
  EEPROM_WRITE(cmin_address,cmins);
  // EEPROM_WRITE(timer_address,timer);

  //EEPROM_WRITE(counter_address, timer_counter);
  finish_flag = 1;
  EEPROM_WRITE(finish_address, finish_flag);
  pwr_interruption = 1; //no power interruption
  EEPROM_WRITE(pwr_address,pwr_interruption);
  lcd_display(csecs,cmins);
  lcd_out(2,7,text);
  lcd_display(secs,mins);
  lcd_out(1,7,text);
  break;
}

if(!start) //if stop pressed

```



```

{delay_ms(1000);
while(!start)
{Heater = 0;
// timer = 0; //clear timer
// TMR1ON_bit = 0;
// timer_counter = 0; //clear timer_counter
secs = 0;
mins = 0;
EEPROM_WRITE(secs_address,secs);
EEPROM_WRITE(mins_address,mins);
csecs = 0;
cmins = 0;
EEPROM_WRITE(csec_address,csecs);
EEPROM_WRITE(cmin_address,cmins);
// EEPROM_WRITE(timer_address,timer);

//EEPROM_WRITE(counter_address, timer_counter);
finish_flag = 1;
EEPROM_WRITE(finish_address, finish_flag);
pwr_interruption = 1; //no power interruption
EEPROM_WRITE(pwr_address,pwr_interruption);
lcd_display(csecs,cmins);
lcd_out(2,7,text);
lcd_display(secs,mins);
lcd_out(1,7,text);
break;

}
delay_ms(400);
// TMR1ON_bit = 0;
Heater = 0;
EEPROM_WRITE(csec_address,csecs);
EEPROM_WRITE(cmin_address,cmins);
finish_flag = 0;
EEPROM_WRITE(finish_address, finish_flag);
pwr_interruption = 1; //no power interruption
EEPROM_WRITE(pwr_address,pwr_interruption);
break;
}
}
}
}

void settings(){
// TMR1ON_bit = 0;
Heater = 0;

if(!set_up)
{delay_ms(400);

```



```
i = 0;
while(!set_up)
{
  mins++;
  if(mins> 99)
  mins = 0;
  EEPROM_Write(mins_address, mins); //write the timer value to EEPROM
  lcd_display(secs,mins);
  lcd_out(1,7,text);
  delay_ms(400);

  i = 1;
}
secs = secs - i;
secs++; //increment timer
if(secs > 59)
{ secs = 0;
  mins++ ;
  if(mins> 99)
  mins = 99;
}
EEPROM_Write(secs_address, secs); //write the timer value to EEPROM
EEPROM_Write(mins_address, mins); //write the timer value to EEPROM
}

if(!set_down)
{ delay_ms(400);
  i = 0;
  while(!set_down)
  {
    if(mins< 1)
    mins = 0;
    else
    mins--;
    EEPROM_Write(mins_address, mins); //write the timer value to EEPROM
    lcd_display(secs,mins);
    lcd_out(1,7,text);
    delay_ms(400);
    i = 1;

  }
  secs = secs + i;
  if(secs < 1)
  {

  if(mins < 1)
  {
    secs = 0;
    mins = 0;
  }
}
```



```

else{
secs = 59;
mins--;

}
}
else
secs--; //increment timer

EEPROM_Write(secs_address, secs); //write the timer value to EEPROM
EEPROM_Write(mins_address, mins); //write the timer value to EEPROM
}
//timer = EEPROM_READ(timer_address);
// delay_ms(10);
mins = EEPROM_READ(mins_address);
secs = EEPROM_READ(secs_address);
timer = mins;
timer = timer << 8;
timer= timer | secs;
lcd_display(secs,mins);
lcd_out(1,7,text);

finish_flag = EEPROM_READ(finish_address);
pwr_interruption = EEPROM_READ(pwr_address) ;
// lcd_chr(2,10,pwr_interruption +48);
// lcd_chr(2,13,finish_flag +48) ;

}

void lcd_display(int sec,int min)
{
text[0] = min/10 + 48; // Extract thousands digit
text[1] = min % 10 + 48;
text[2] = ':' ;
text[3] = sec/10 + 48;
text[4] = sec% 10 + 48;
}

```

References

- [1]. Aamir, Shahzad, Teyyiba, Kanwal & Mao-Gang He (2013). 'Design and Development of Efficient Domestic Electric Cum Solar Oven'. Journal of Basic & Applied Sciences. Vol. 9, Pp. 296-301.
- [2]. Kumar, P.R. (2001). "New technological vistas for systems and control: the example of wireless networks," IEEE Control Systems Magazine. Pp. 24-37.
- [3]. Adegbola, A.A., Adogbeji, O.V., Abiodun, O.I., & Olaoluwa, S. (2012). 'Design, Construction and Performance Evaluation of Low Cost Electric Baking Oven'. Innovative Systems Design and Engineering. Vol 3, No.11, Pp. 38-49.
- [4]. George, Dales (1974), 'Excavations at Balakot, Pakistan, 1973'. Journal of Field Archaeology (Boston University) 1 (1-2):3-22.



- [5]. Juang, C.F. (2003). An automatic building approach to special Takagi-Sugeno fuzzy network for unknown plant modeling and stable control, *Asian J. Control*, 5 (2), 76-186
- [6]. Chukwuedozie, N. Ezema & Chukwuebuka, B. Umezinwa (2016). 'Design and Implementation of a Microcontroller –Based Digital Time Aware Oven Temperature Controller with Display. *International Journal of Multidisciplinary Research and Modern Education (IJMRME)*. Vol. II, Issue I. Pp.371-379.
- [7]. Harmim, H., Boukar, M., Amar, M. (2008). 'Experimental Study of a Double Solar Cooker with Finned Cooking Vessel' *Solar Energy*; 82: Pp.287-89.
- [8]. Kumar, N., Agravat, S., Chavda, T., Mistry, H. N. (2008). 'Design and Development of Efficient Multipurpose Domestic Solar Cookers/Dryers'. *Renewable Energy*; 33: 2207-11.

